



The Ultimate Guide
to Pipeline Pigging

Various Enduro Pigs and Pigging Information



Running pipeline cleaning pigs on a regular basis is very important for many reasons; maintain the pipelines integrity, increase pipeline throughput, maintain continuous operation, provide timely information of developing problems, and to prepare and preserve pipeline cleanliness for internal smart pig inspections. However, prior to running cleaning pigs many important factors must be considered:

- Minimum bend radii (1.5D, 2D, 3D, etc...)
- Minimum and maximum wall thickness
- Line length
- Product being transported during time of pigging
- Normal and maximum operating pressure
- Estimated flow rate
- Type and amount of debris expected to be removed
- Prior pigging operations performed (includes frequency and type of pigs used)

Generally speaking, Enduro offers many types of pig configurations, including Custom designs to specifically meet the Customers pipeline needs. Enduro offers pigs ranging in sizes from 2-inch through 60-inches in diameter, including dual diameter pigs. Each pig can be equipped with cups, discs, brushes, magnets, tracking devices, or a combination there of. Moreover, varying hardnesses of urethane durometer are available for different applications.

Other modifications such as adjusting pig lengths for safe transitions through valves and lateral connections can also be accomplished. Furthermore, dependant upon each pipelines specific makeup, Enduro can add bi-pass ports through the pigs to aid in debris removal. Customers are encouraged to complete an "Enduro Pigging Questionnaire" for each line section that requires pigging. Enduro will review the completed questionnaire and make the

appropriate pigging recommendations based on information the Customer provides.

Pipelines that have been routinely pigged can usually incorporate other pig designs that are slightly more aggressive in nature than what has typically been run. For instance, if a combination, cup and disc pig is utilized on a monthly basis with little or no debris being retrieved, the Customer could then potentially increase the pigs effectiveness by adding brushes or another pig section all together. However, pipelines which have not been frequently pigged, or that have never been pigged should be approached with careful consideration.

Typically, these types of pipelines will need to incorporate a progressive pigging program, requiring the first pig passes to be accomplished by using less effective pigs than the later pig passes. Initially the line should be pigged with a tool that is relatively risk free, designed for light duty cleaning, safely pass 1.5D bends, most restrictions, and will prove the line piggable (all pig configurations when run for the first time should be equipped with a transmitter for tracking and locating purposes).

Once the “prover” pig has been received in good condition and little or no debris is retrieved, the customer can then progress to the next pigging configuration which will be slightly more aggressive than the last. This process will be repeated until the final cleaning pig stage is reached which will usually incorporate an aggressive cleaning pig train equipped with a combination of cleaning elements such as cups, discs, brushes, blades and magnets.

When the line has been determined to be clean, the Customer can then proceed on to the next phase of the pigging program which will require running Enduro’s Digital Geometry Tool (DdL). Once the caliper phase has been completed, Enduro’s Digital Flux Logger (DfL Corrosion Tool) should then be implemented. Finally, upon the successful running of the DfL tool, a regularly scheduled pigging program should be implemented to prevent the reoccurrence of debris build-up, and to keep the line prepared for future in-line inspection operations.

Next are various pictures of a few Enduro pigs that can be utilized for petroleum or other pipeline cleaning and maintenance applications.

1. Pigs recommended for *stage one* cleaning programs and proving operations; light to moderate cleaning (Pigs are shown from least to most aggressive).

1a. Foam pigs are available in light, medium and heavy densities. Bare swabs, urethane coated and brushes are available.



1b. Urethane cleaning pigs are equipped with two conical cups and are bolted onto a metal pig mandrel. Ideal for proving, tracking and light duty cleaning applications. Brushes, magnets, and blades can be added to enhance the pigs cleaning abilities. All Enduro brushes will provide 360° of internal pipe wall coverage.

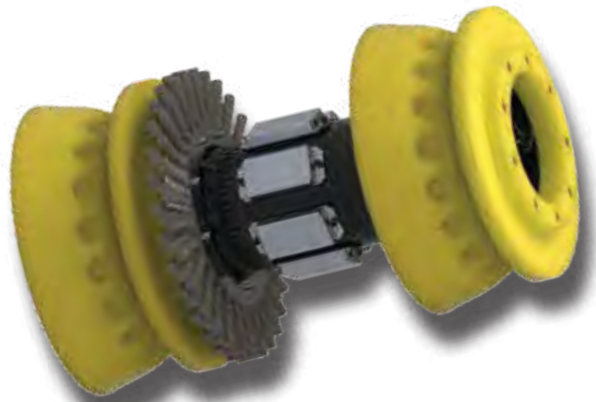

2. Pigs recommended for *stage two* cleaning programs and routine maintenance; moderate to heavy cleaning.

2a. STS-4CC pigs are typically used for nitrogen purges, batching and regular duty cleaning applications (also available with three cups).



2b. Enduro UreCast pigs are constructed of 100% urethane and are equipped with (2) cups and (2), or in some cases, (3) scraper discs. The UreCast can be equipped with wrap brushes and is ideal for purging, batching, cleaning and tracking applications.

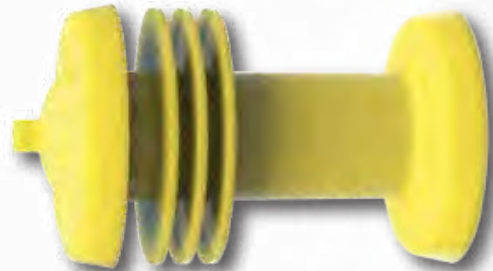

2c. BI-DI pigs are commonly used as fill and de-watering pigs during hydro-static testing operations. They can also be used as cleaning, batching and displacement pigs when bi-directional applications are necessary. Typically, BI-DI pigs are equipped with as little as two discs and as many as eight. Wrap brushes and magnets can also be added to the BI-DI pig to enhance its cleaning abilities.



3. Pigs recommended for *stage three* cleaning programs and routine maintenance; heavy to aggressive cleaning.

3a. Multi-section pig trains are often run as the final pigging configuration prior to starting inline-inspection runs. These pig trains are commonly configured as two, three and sometimes four section trains (length and amount of cleaning elements are dependant upon pipeline bend radii and barrel lengths). The additional amount of cups, discs, brushes and magnets make pig trains extremely aggressive, allowing the pig to accomplish excellent cleaning results. Pig sections are typically coupled together by urethane Pig Links or metal u-joints. Shown here is one type of pig train configuration, available to aggressively clean most any pipeline.



4. Dual diameter cleaning, batching and gauging pigs for multi-diameter pipe runs.

4a. Dual diameter pigs ranging in sizes from 3" x 4" to 36" x 48" are also available at Enduro. Dual diameter pigs can be equipped with discs, cups, brushes blades and magnets. Each dual diameter pig is designed to achieve maximum seal in multidiameter pipe and the spring loaded brushes / blades are designed to be effective in all diameters, providing 360° of internal pipe wall coverage. Shown is one example of our Enduro dual diameter pig designs.



As a reminder, Enduro will treat each and every pipeline on an individual basis; no two pipeline atmospheres are the same. Therefore, it is imperative to provide as much detailed information as possible for each pipeline section that requires pigging. As stated earlier, this can be accomplished by completing an Enduro Pigging Questionnaire and submitting it to an Enduro representative for review. Once the gathered information has been processed, Enduro will provide the best solutions available for solving all our customers pipeline needs.

Digital Data Logger (DdL™)

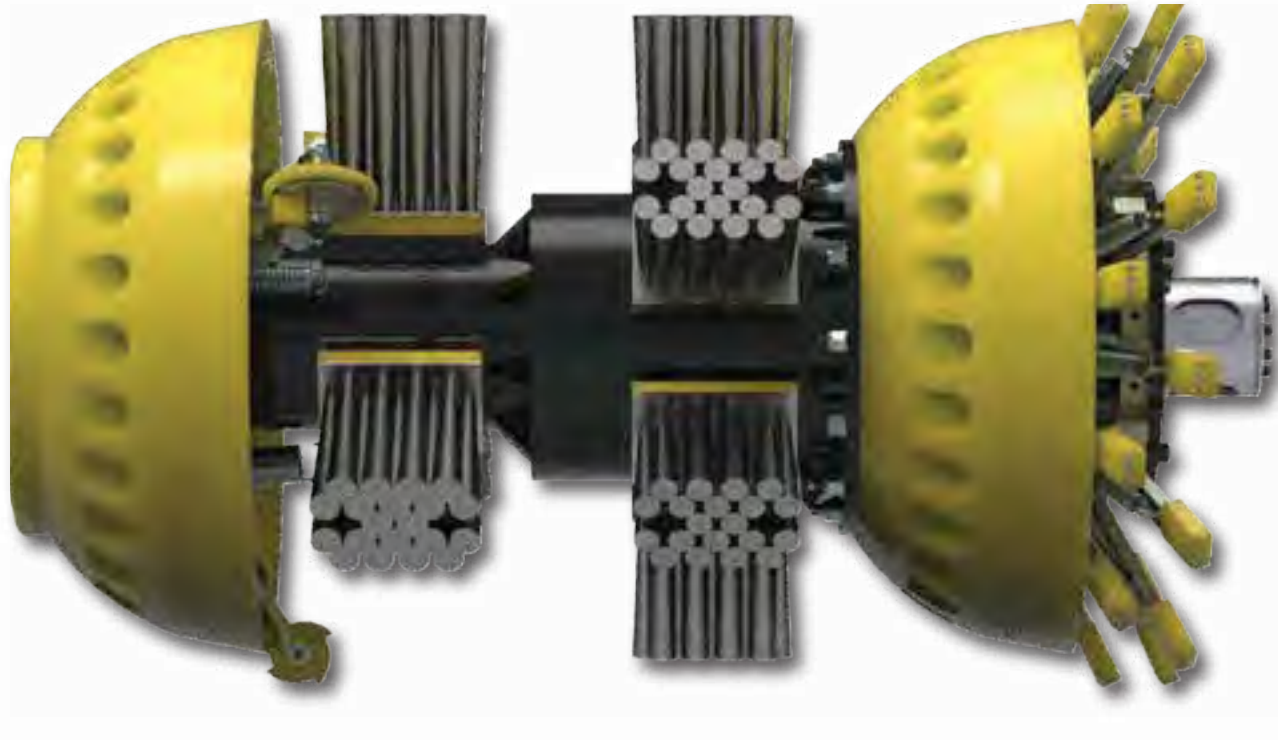

The ENDURO Digital Data Logger™ provides both radius point readings and diametrical cross-sectional analysis; multiple channels are provided offering the ability to log pipeline anomalies in clock orientation. Twin gyro inputs provide the ability to assess bend radii and bend direction (up from down – left from right); the angle of the

bend is also determined. ENDURO's DdL™ equipment is capable of traversing and reading bend radii of normal radius of 1.5 times pipe diameter; bends of 1 diameter have been logged with special tool adaptation. Tool sizes range from 4 inch through 60 inch plus dual and multiple diameter designs.

Digital Flux Logger (DfL™)

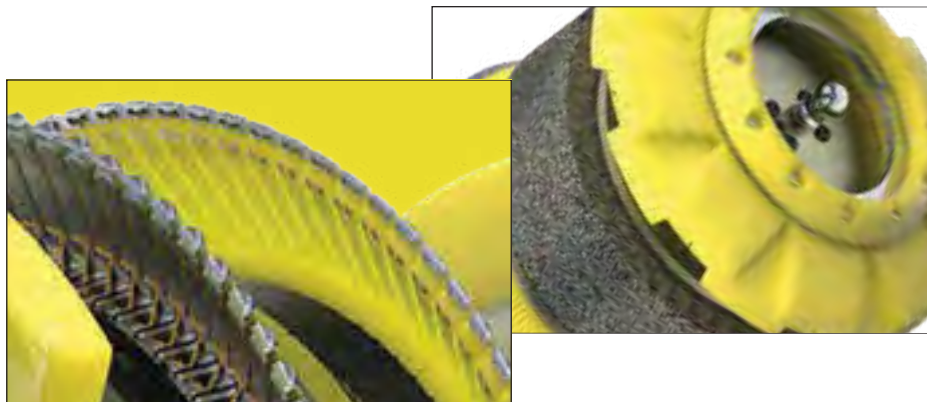
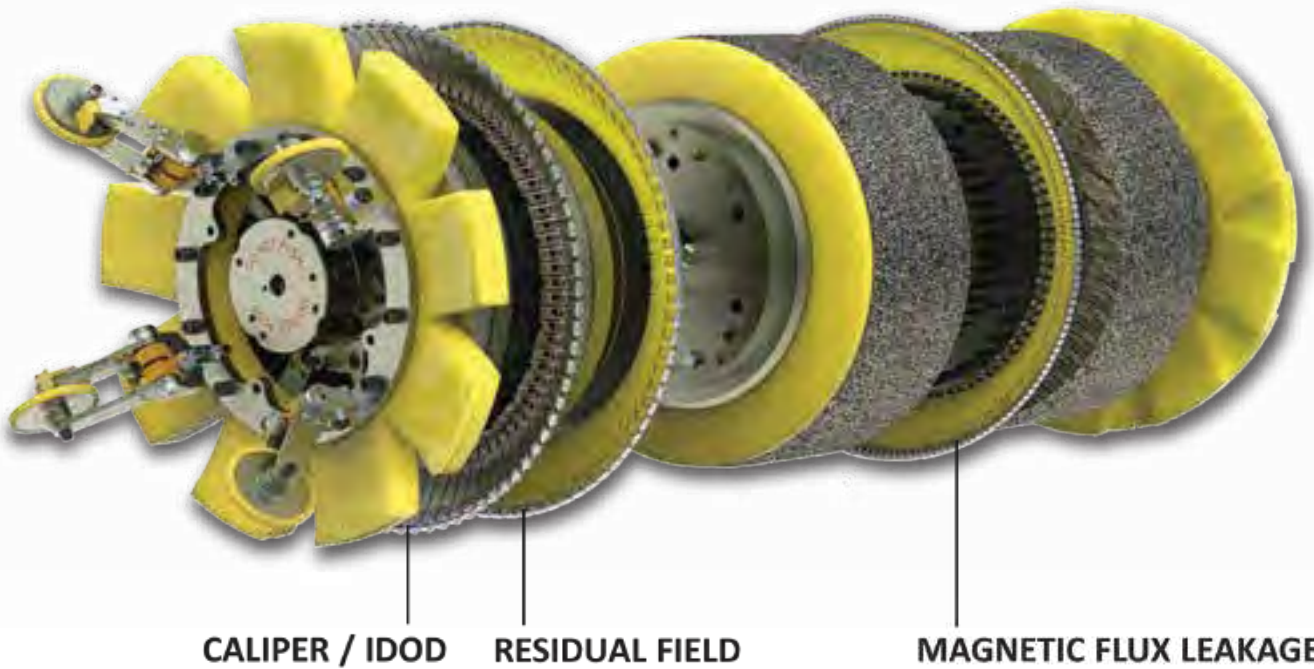

Enduro's complete Pipeline Integrity Service utilizes our DfL™ multi tool's ability to acquire data from several sources at one time in one pass, allowing our analysts to compare/analyze each data set. The result, to more readily recognize all pipeline features, geometry and/or metal loss indications plus

simultaneously evaluate for profile, deformation, strain, and permeability variations. Our Enduro single pivot sensors have the ability to record very small Deformation and Metal Loss with one tool and confirm these indications with our single analysis Pig Prog II Presenter™ software program.

PigProg II Presenter™ Software

- Interactive Graphics and Database
- Multiple Visualization Formats
- Customized Report Formats
- Operator Specified Assessment Codes
- Operator Specified Interaction Rules

Digital Data Logger (DdL DW2™)

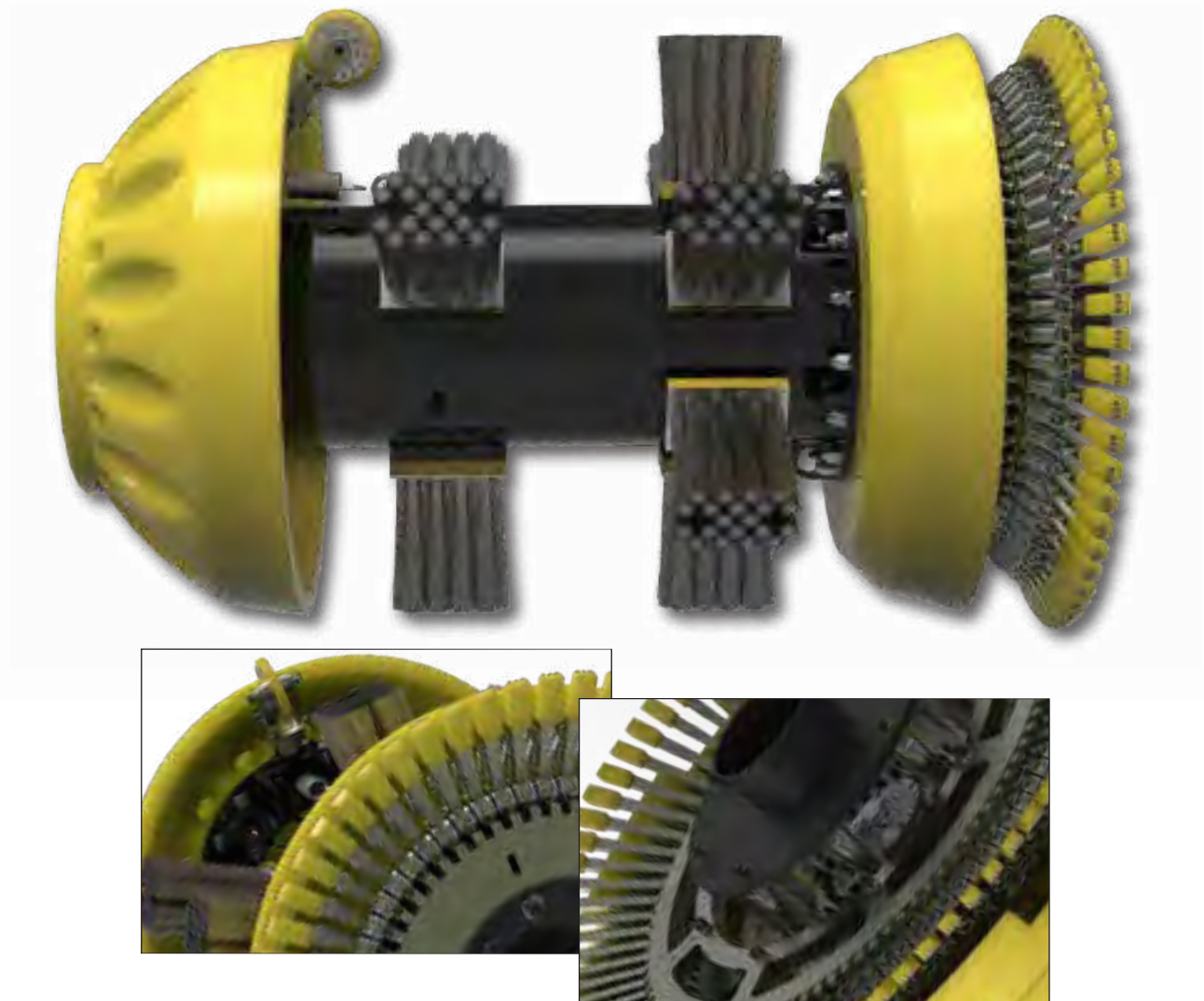

Our newly developed Digital Data Logger DW2™ ILI (the DdL DW2™) pig features advanced IMU navigation equipment that complements our PigProg software containing GIS tools that connect to a system utilizing ArcGIS. Pipeline operators are becoming very familiar with new regulations pertaining to CFR 192 and 195 compliance. Pipelines affected by these new regulations will need accurate mapping along with moderate consequence area (MCA) determination. Natural gas gathering and transmission pipelines also need to be updated. Moreover, urban sprawl and growing suburban neighborhoods are putting businesses and people into the 100-yard, 220-yard, and the

potential impact radius (PIR) extents of active pipelines. With Enduro's advancements in GIS, Class location, HCA, and MCA determination for Natural Gas pipelines is now a service we are offering. Enduro also has the expertise and tools to work with liquid pipeline operators for HCA determination using the Unusual Sensitive Area (USA) licensed datasets. As part of HCA determination for liquid pipelines, Enduro will provide overland spill analysis. With accurate up-to-date HCA, MCA, and Class location analysis we can better support our client's Integrity Management Plans (IMP). Regulatory analysis is provided in the final report, and we can provide the Spatial deliverables for GIS Integration.

Pigging Example

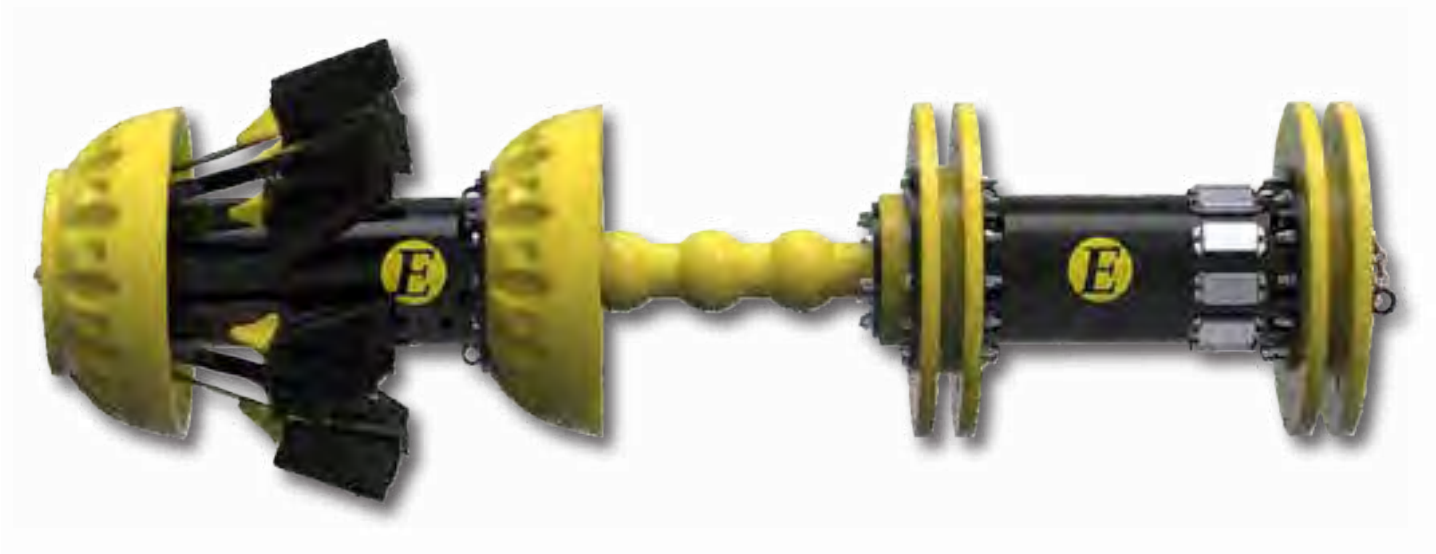

24" ADV -2CC-BR/PL/4D-MG

Natural Gas Pipeline – Iron Oxide Removal



Pigging Example

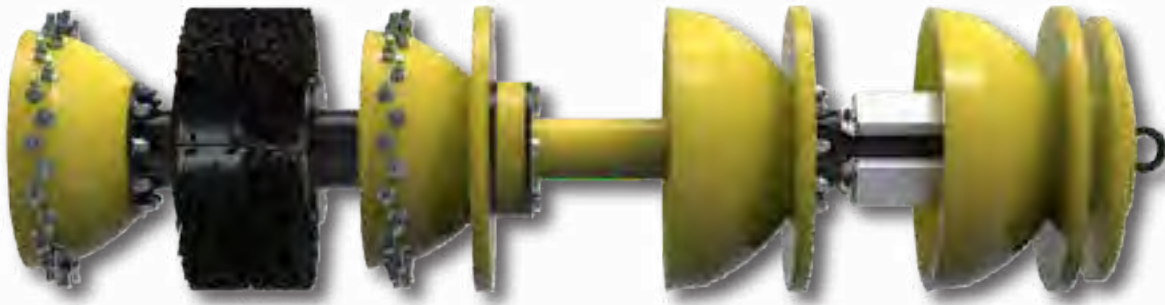

12" ADV-3D-2CC-MG/PL/1D-2CCSTD-BRW Pig Train

Crude Oil – Paraffin Removal



Enduro Product Components

Enduro manufactures components using MDI Urethane, (Methylene Diphenyl Diisocyanate).

MDI - a superior urethane material to use inside your pipeline.

Simply stated, the chemical makeup gives longer wear life, more elasticity, increased tensile strength and better tear resistance. Competitors use TDI Urethane, (Toluene Diisocyanate) - it costs less and is easier to pour into shapes. TDI does not provide the above listed benefits of Enduro MDI Urethane.

Enduro believes only the best products should go into your million or billion dollar pipeline assets. Therefore, we strive to manufacture our pigs using the best materials and MDI urethane components available. We firmly believe our products perform better; thus outlasting our competitor's urethane components. Coupled with our approach to quality; is an 'unmatched' service and supply response delivery time - best in the industry.

CHART LISTING OF URETHANE PROPERTIES				
Compound	Molar Mass (g/mol)	Melting Point (deg. C)	Boiling Point (deg. C)	Flash Point (deg. C)
TDI	174.2	21.8	251	127
MDI	250.25	40	314	212-214

One sees that the molar mass (or molecular mass or the molecular weight) of TDI is less than MDI. Chemicals that have lower molecular weights tend to volatilize (i.e. vaporize) and more readily produces more vapors or fumes from the temperature based on a comparison of the molecular weights (molar mass).

The melting point, boiling point and flash point for TDI are all lower than for MDI. This also suggests that TDI is more likely to volatilize or vaporize at lower temperatures and produce more chemical fumes than MDI.

Therefore, TDI appears to be more likely to produce chemical vapors and fumes in comparison to MDI and would likely be a more dangerous chemical to handle in regards to inhalation health hazards.

Recommended Pipeline Pig Maintenance Procedure

ENDURO Pipeline pigging products are manufactured to the highest quality standards available and warranted against defective material and workmanship. The Urethane formulated at ENDURO is designed to provide you with high wear resistance with increased scraping and sealing performance.

URETHANE PHYSICAL PROPERTIES:

Hardness: 75, 85 or 95 shore A scale
Elongation: 570%
Tear: 500 PLI
Tensile: 6200 PSI
Rebound: 35%
Temperature: -60° F to 200° F
Abrasion: 20 milligrams loss ASTM test

STORAGE:

Although the ENDURO MDI-based Urethane provides maximum resistance to ultra-violet rays and hydrolysis, it is recommended that pigs and pig cups be stored out of direct sunlight in a low-heat, low humidity environment. It is recommended that shelf-life of stored parts not exceed 1-year. Stacking of multiple Urethane parts that distorts the part shape should be avoided. Covering with non-translucent material such as black plastic with a moisture absorbent desiccant is recommended.

WEAR LIFE:

New pig cups and scraper disc are usually much larger than the pipe internal diameter. For example, a 20" may have a 20" O.D. for a 20" pipeline. This gives additional scraping against

the pipe interior and allows for better cup seal for most pipe wall thickness applications. Due to this oversized diameter, the cup wear will be accelerated initially until the cup O.D. approaches the pipe I.D. When this occurs, the cup wear rate is greatly reduced thereby giving a longer wear life. Dependant upon the application, the cup/disc may need to be replaced at different intervals.

CUPS/DISCS MEASUREMENT METHOD:

Normally, the cup/disc diameter measurement is taken by stretching a tape measure across the diameter and reading that dimension. If this method is used, the diameter should be measured at several locations while averaging the diameters taken. It is not unusual to find cups/disc slightly out of round. A more exact cup diameter measurement may be made by measuring circumference and then dividing by 3.143 or by using a PI tape, which converts the circumferential measurement to diameter. The circumferential measurement may be made on assembled pigs when a diameter measurement cannot be made due to the cup body mount. Dependant upon the application, the wear life of a cup or disc may run 100-500 miles. Pipelines containing lubricants such as oil, crude, kerosene, diesel fuel and water usually give extended wear-life to a pig cup or disc. Dry-sandy pipelines or dry liquid lines such as natural gas, gasoline, or propane usually accelerate the wear thereby decreasing the wear-life.



In a batching or displacement application, when the sealing characteristic of a cup or disc is critical, the cup/disc diameter should exceed the largest pipe internal diameter. In cleaning applications, the cup/disc may be considered reusable when the outside cup diameter is slightly less than the pipe internal diameter.

DISMANTLING AND REASSEMBLY OF CLEANING PIGS:

After every cleaning run, each pig should be cleaned and closely inspected to ensure even wear of the components and ensure there is no damage to any of the components on the pig.

If the pig is going to be rebuilt, once the ESNA nylock nuts are removed, they should be

discarded. Enduro does not recommend reusing the ESNA nylock nuts when reassembling the pig.

Once the new urethane components are placed in proper order on the pig body, the bolts should be tightened down snugly, tightening in a star pattern. Enduro does not recommend using impact wrenches of any kind when tightening the bolts. However, if tightening with a torque setting, the setting should be set to 10. Once all bolts are tightened to this setting, you should manually go around each bolt to ensure they are snug. This setting was determined using an 18V Dewalt Torque Wrench. When tightening with other tools, this setting may need to be slightly adjusted. The urethane should never be tightened down tight enough that it is causing the urethane to stretch. When the bolts are tightened, a visual inspection should be performed to ensure that there are approximately the same number of threads from the bolt, protruding past the nylock nuts.

VISUAL APPEARANCE OF OVERTIGHTENED BOLTS:

- The metal flange that the urethane is setting on will be cutting into the underneath side of the urethane components.
- If using urethane disc, the disc will have a bowed appearance.
- Tightening the urethane too much will cause the bolt holes to elongate, weakening the material around the bolt holes.

Operation Sequence For Launching Pigs - Liquid Service

Starting Condition: Trap is pressurized and full of liquid; Valves A, B, and C are open. Valves D and E are closed.

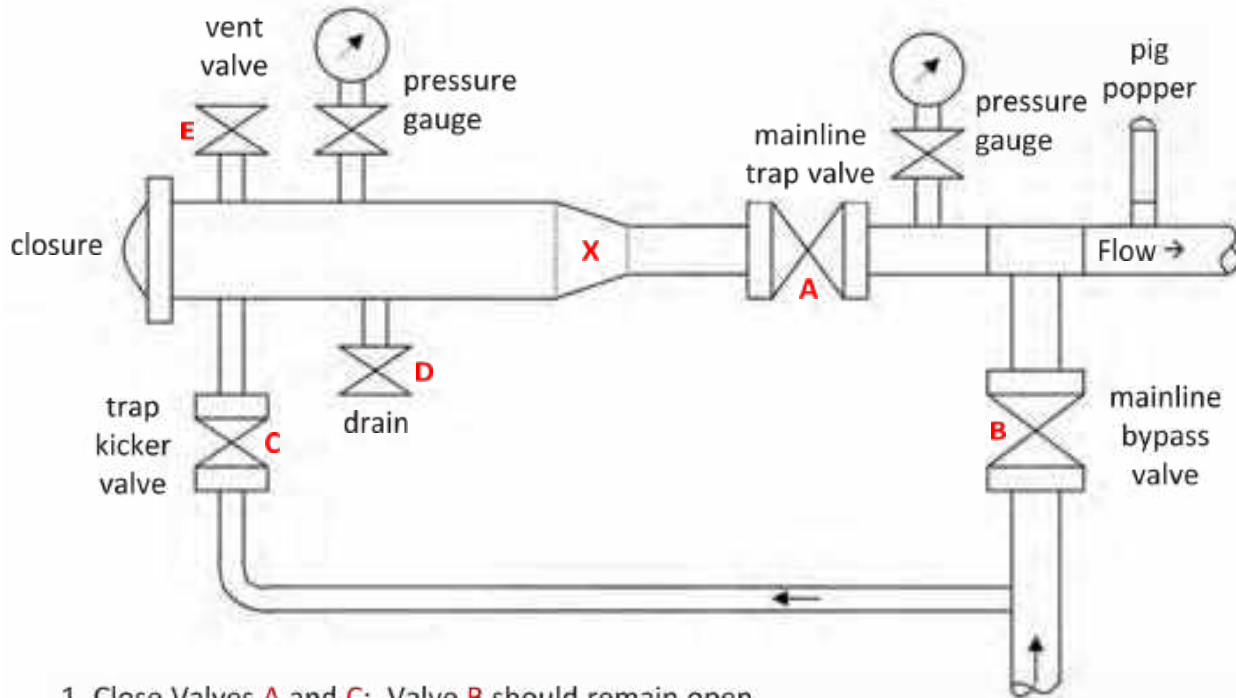

1. Close Valves A and C; Valve B should remain open.
2. Drain the launch trap by opening Valve D and allow air to displace the liquid by slowly opening Valve E.
3. When the trap is completely drained (0 psig) with Valves D and E still open, open the closure door and insert the pig so the first cup forms a seal in the reducer (X).
4. Close and secure the closure door. Close Valve D and leave Valve E open. Slowly fill the trap through Valve C by venting the air through Valve E. When filling is completed, close Valve E to allow pressure to equalize, then close Valve C.
5. Open Valve A, then Valve C. The pig is now ready for launching. **The pressure upstream and downstream of Valve A should be the same before opening Valve A and C.**
6. Partially close Valve B. This will increase the flow of liquid through Valve C and behind the pig. Continue to close Valve B until the pig moves out of the trap into the mainline stream as indicated by the Pig Popper.
7. When the pig leaves the trap and enters the mainline, fully open Valve B.

The operating sequence described above is for general information only; this is not intended to nor should it be used for training pigging systems operators.

Operation Sequence For Receiving Pigs - Liquid Service

Starting condition - Trap is empty at atmospheric pressure. Valve **B** is open.
Valves **A** and **C** are closed. Closure door is closed and secured.

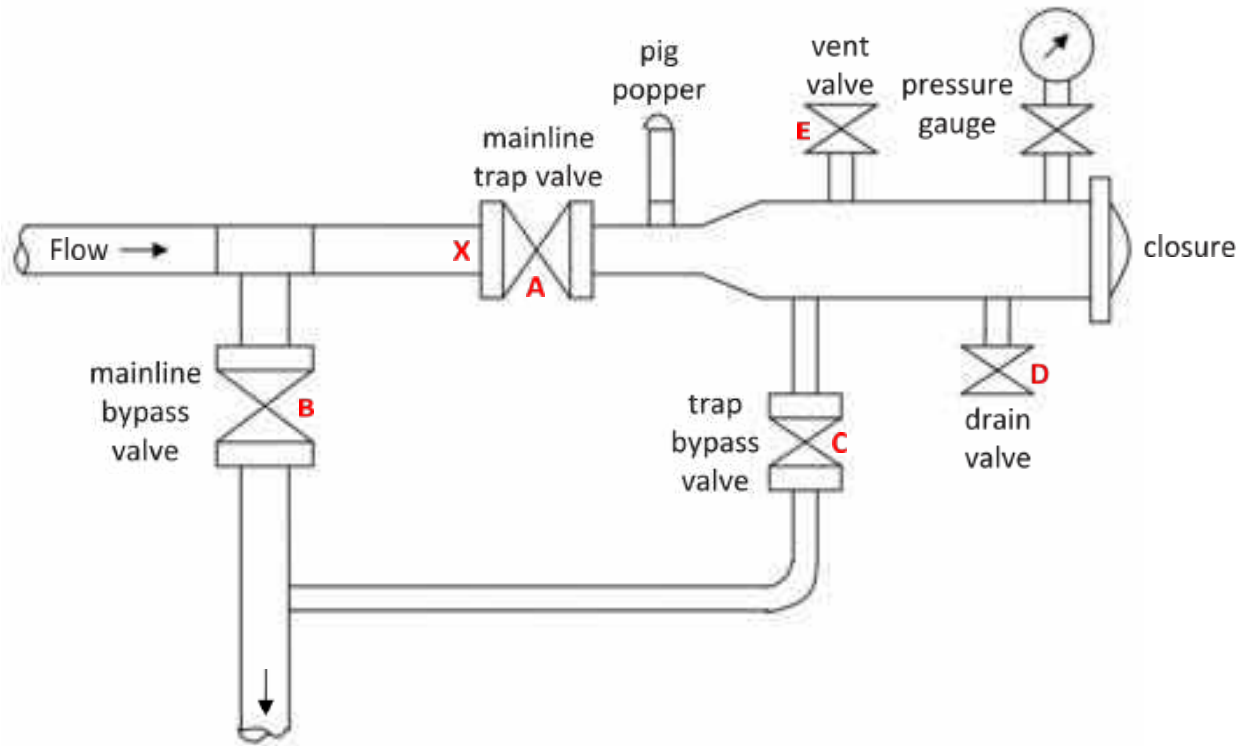

1. Close drain Valve **D**. Slowly fill the trap by opening Valve **C**, venting through Valve **E**.
2. Close vent Valve **E** to allow trap pressure to equalize through Valve **C**.
3. With Valve **C** open, open Valve **A**. Trap is now ready to receive pig.
4. When the pig arrives, it may stop between trap Valve **A** and the Mainline Bypass Valve **B** (point **X**).
5. Partially close Valve **B**. This will force the pig into the trap due to increasing flow through Valve **C**.
6. When the pig is in the trap as indicated by the Pig Popper, open Valve **B** completely and close Valves **A** and **C**.
7. Open drain Valve **D** and vent Valve **E** and drain the trap.
8. After the trap is fully drained (0 psig) with Valves **D** and **E** still open, open the closure door and remove the pig.
9. Close and secure the closure door.

The operating sequence described above is for general information only; this is not intended to nor should it be used for training pigging systems operators.

Operation Sequence For Launching Pigs - Gas Service

Starting Condition: Trap is pressurized and full of gas; Valves **A**, **B**, and **C** are open

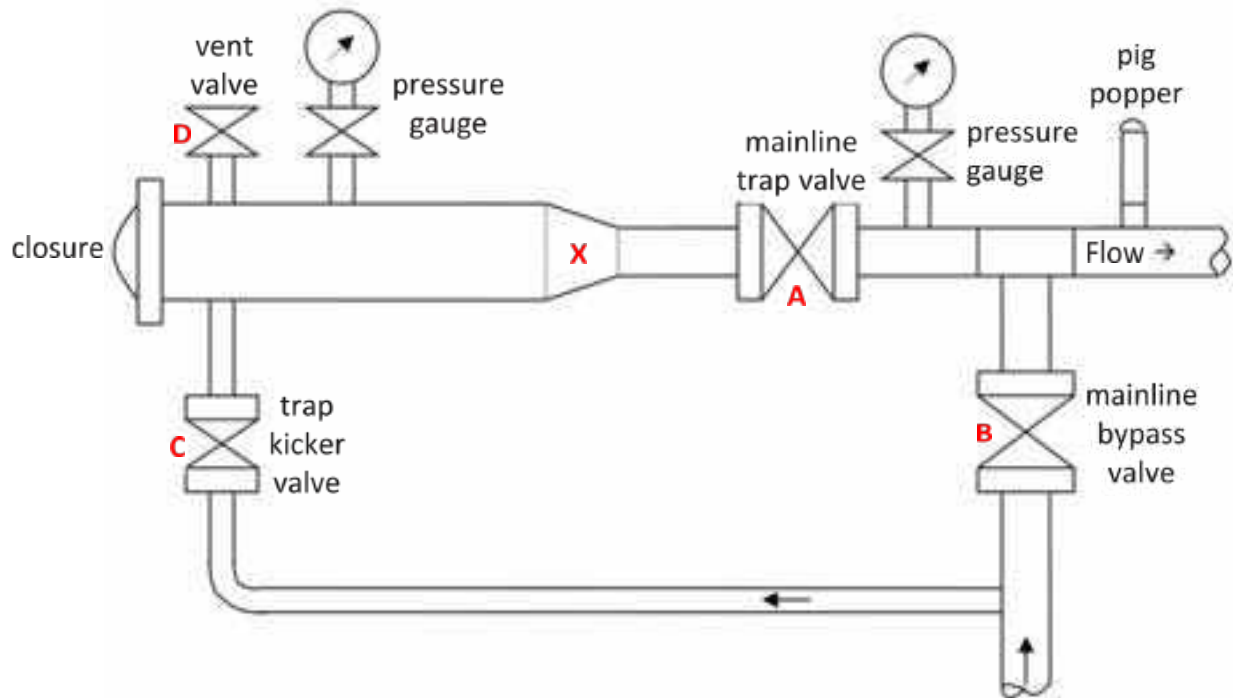

1. Close Valves **A** and **C**; Valve **B** should remain open.
2. Open Valve **D** to vent launching trap to atmospheric pressure.
3. When trap is completely vented (0 psig) with Valve **D** still open, open the closure door and insert the pig so the first cup forms a tight seal in the reducer (**X**).
4. Close and secure closure door. Purge air from trap through Valve **D** by slowly opening Valve **C**. When purge is completed, close Valve **D** to allow pressure to equalize. Then close Valve **C**.
5. Open Valve **A**, then Valve **C**. The pig is now ready for launching. **The pressure upstream and downstream of Valve A should be the same before opening Valve A and C.**
6. Partially close Valve **B**. This will force increasing flow through Valve **C** and behind the pig. Continue to close Valve **B** until the pig moves out of the trap into the mainline stream as indicated by the Pig Popper.
7. When the pig leaves the trap and enters the mainline, fully open Valve **B**.

The operating sequence described above is for general information only; this is not intended to nor should it be used for training pigging systems operators.

Operation Sequence For Receiving- Pigs - Gas Service

Starting condition trap is empty at atmospheric pressure. Valves **B**, **D**, and **E** are open. Valves **A** and **C** are closed. Closure door is closed and secured.

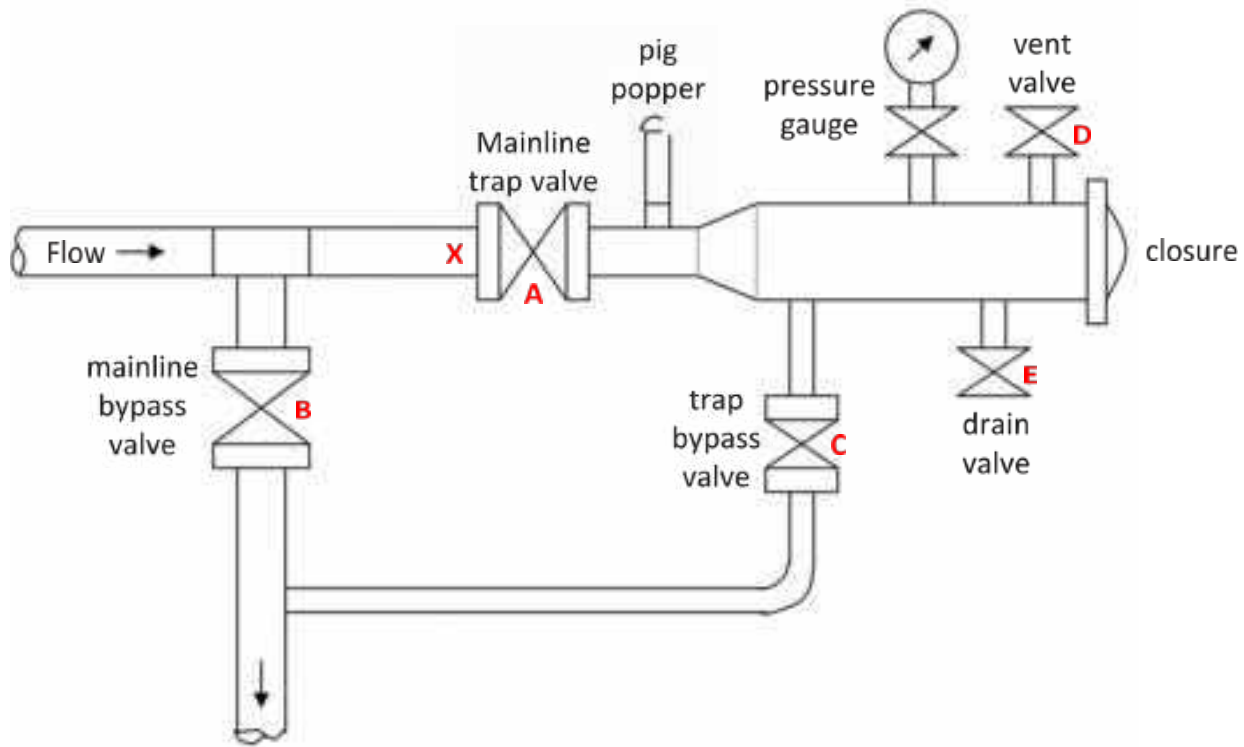

1. To purge trap, close Valve **E** and slowly open Valve **C**.
2. After purging, allow trap pressure to equalize by closing Valve **D** with Valve **C** open.
3. With Valve **C** still open, open Valve **A**. The trap is now ready to receive the pig.
4. When the pig arrives, it may stop between trap Valve **A** and the Mainline Bypass Tee (point **X**).
5. Partially close Valve **B**. This will force the pig into the trap due to increasing flow through Valve **C**.
6. After the pig is in the trap as indicated by the Pig Popper, open Valve **B** and close Valves **A** and **C**.
7. Open Valves **D** and **E** and vent the trap to atmospheric pressure.
8. After the trap is vented (0 psig) and drained with Valves **D** and **E** open, open the closure door and remove the pig.
9. Close and secure closure door.

The operating sequence described above is for general information only; this is not intended to nor should it be used for training pigging systems operators.

Pigging/Presurvey Questionnaire

Company: _____

Division: _____

Address: _____

Contact Name: _____

Email: _____

Office Phone: _____

Fax Number: _____

Cell Phone: _____

Pipeline System Name: _____

Customers are requested to complete a PreSurvey Form for each pipeline section to be surveyed.



P.O. Box 3489 • Tulsa, OK 74101-3489 • 800-752-1628
www.enduropls.com • 918-446-1934 • fax 918-446-8125

Pigging/Presurvey Questionnaire

TYPE OF SURVEY	
<input type="checkbox"/>	AGM Site Documentation - determination and GPS collection of AGM locations
<input type="checkbox"/>	Enduro Caliper DdL™ Survey – Geometry/Bend/Weld Logging
<input type="checkbox"/>	Enduro MFL DfL™ COMBO Survey, MFL Axial Field – Metal Loss/Geometry/Bend
<input type="checkbox"/>	GPS Mapping; providing GPS coordinates for all logged events
<input type="checkbox"/>	Pig based GIS As-Built Mapping (Alignment Sheets)
<input type="checkbox"/>	If yes, do you have ortho-photo backgrounds that may be used?
<input type="checkbox"/>	Tracking – Cleaning Pigs
<input type="checkbox"/>	Tracking – Caliper DdL™ Survey
<input type="checkbox"/>	Tracking – MFL DfL™ COMBO Survey

PIPELINE SECTION	
1st Diameter:	2nd Diameter(if dual diameter):
Length:	Length:
<i>Additional Comments:</i>	

PIPELINE LOCATION				
	Launcher		Receiver	
City			City	
County			County	
State/Province			State/Province	
Country			Country	

PRODUCT					
In Service:			Known Previous Products:		
During Survey:		Speed:	Operating Pressure:		Temp:
Paraffin %:	BS&W%:	H ₂ S%:	H ₂ O%:	CO ₂ %:	
<i>Are there any PCB contaminates or other Safety and Environmental concerns related to this pipelineand/or product? (please describe)</i>					

Pigging/Presurvey Questionnaire

CLEANING MAINTENANCE	
Pig Type:	Debris Removed:
Frequency:	Typical Amount of Debris Removed:
Amount of Cup Wear:	Date of Last Cleaning Pig Run:
Has any chemical cleaning been performed on this pipeline? <input type="checkbox"/> Yes <input type="checkbox"/> No	
If yes, please list the date and the procedures utilized during the chemical cleaning process:	

PIPELINE HISTORY	
Year of Construction:	
Most recent survey type/date:	Caliper Pigging <input type="checkbox"/> Corrosion Pigging <input type="checkbox"/>
Has the pipeline(s) experienced long seam problems in the past? <input type="checkbox"/> Yes <input type="checkbox"/> No	
If yes, please explain:	

PIPELINE WALL THICKNESSES AND PIPE GRADE					
Wall Thickness	Length	MAOP (MOP)	SMYS	Pipe Type	Pipe Grade
Is the pipeline internally coated? <input type="checkbox"/> Yes <input type="checkbox"/> No					
Additional Comments:					

Pigging/Presurvey Questionnaire

LAUNCH AND RECEIVE TRAP DETAILS

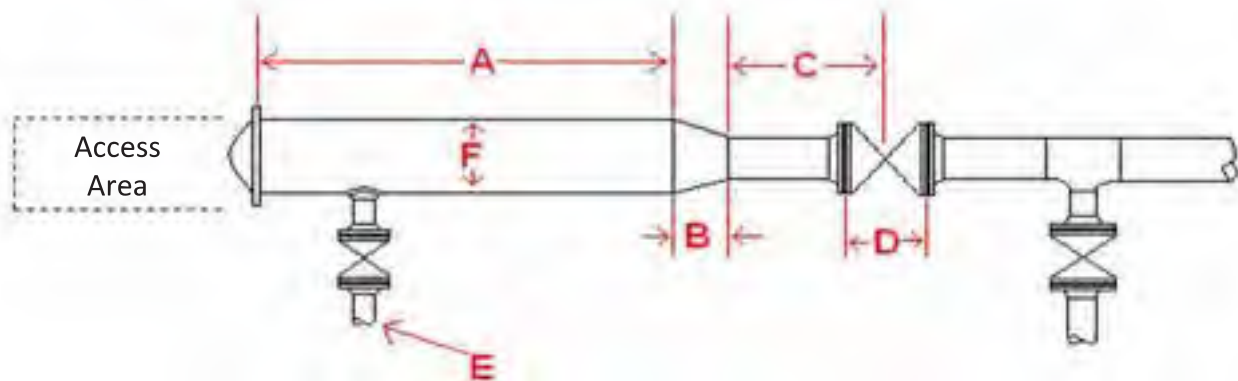

	Launcher	Receiver
Length of Oversize (A)		
Type/Length of Reducer (B)		
Length of Nominal Pipe (C)		
Length of Trap Valve (D)		
O.D. of Kicker/Bypass (E)		
O.D. of Oversize (F)		
I.D. of Oversize (F)		
Access Area (L x W)		
Height (ground to bottom of pipe)		
Hoist Available	<input type="checkbox"/> Yes <input type="checkbox"/> No	<input type="checkbox"/> Yes <input type="checkbox"/> No

MAINLINE VALVES - BLOCK, GATE, BALL, ETC.

Type	Quantity	Manufacturer	Model No.	Min. I.D.	Bowl Length

Additional Comments:

Does the pipeline contain Orbit Valves or Plug Valves? Yes No

If yes, a spec. sheet for each valve will be required.

Pigging/Presurvey Questionnaire

CHECK VALVES					
Type	Quantity	Manufacturer	Model No.	Min. I.D.	Bowl Length
Additional Comments:					
Can the Check Valve(s) be pinned open during the survey? <input type="checkbox"/> Yes <input type="checkbox"/> No					

BENDS			
Quantity	Min. Radius	Min. I.D.	Comments
Additional Comments:			

TEES AND BRANCHES					
Type	Quantity	Outside Diameter	O'clock Position	Pig Bars	Comments
Additional Comments:					
All flow tees should be closed during the survey.					

Pigging/Presurvey Questionnaire

CORROSION TOOL VENDOR AND SPECIFICATIONS OF THE CORROSION TOOL TO BE USED	
This information is required for Enduro to provide a Caliper "Field Report"	
Corrosion Tool Vendor	
Minimum I.D. in Straight Line Pipe	
Minimum I.D. through a Line Valve/Fitting	
Minimum I.D. through a Bend	

PRESSURE CALCULATIONS
Select one of the following: <input type="checkbox"/> B13G <input type="checkbox"/> Modified B13G
Specify one of the following:
Operating Pressure: MAOP/MOP:
Specified Minimum Yield Strength: Design Pressure:
<i>The pipe grade data is used to determine the Burst Pressures and P-Safe Values. If the pipe grade data is not supplied, all calculations will be run with a 0.72 Safety Factor/Density Class 1.</i>

RULES OF INTERACTION			
Select one of the following:			
Axial Spacing:	<input type="checkbox"/>	if space is less than or equal to	inches
	<input type="checkbox"/>	if space is less than or equal to	times wall thickness
Circumferential Spacing:	<input type="checkbox"/>	if space is less than or equal to	inches
	<input type="checkbox"/>	if space is less than or equal to	times wall thickness

CUSTOMER REQUIREMENTS OR ADDITIONAL COMMENTS

Pigging/Presurvey Questionnaire

CONTACT LIST FOR PROJECT			
Name	Title	Phone	Cell

ADDRESS AND/OR DIRECTIONS TO LAUNCHER AND/OR RECEIVER

CONTACT INFORMATION FOR INVOICING
Address:
Contact Name and Number:

CONTACT INFORMATION FOR FINAL REPORTS
Address:
Contact Name and Number:

CONTACT INFORMATION FOR SHIPPING
Address:
Contact Name and Number:



P.O. Box 3489 • Tulsa, OK 74101-3489 • 800-752-1628
www.enduropls.com • 918-446-1934 • fax 918-446-8125

We're Cleaning, Data Logging,
Pigging, Gauging, Tracking, Data
Storage, Purging, ILI, Monitoring, GIS,
Batching, and Data Analysis.



We're



ENDURO
PIPELINE SERVICES, INC.



P.O. Box 3489 • Tulsa, OK 74101 • 5002 S. 45th W. Ave. • Tulsa, OK 74107
800-752-1628 • 918-446-1934 • www.enduropls.com • info@enduropls.com

